

# KALEIDOS

Kaleidos was born from the harmonious meeting of different minds and components: a system that reflects, like a kaleidoscope, the beauty of collaboration.

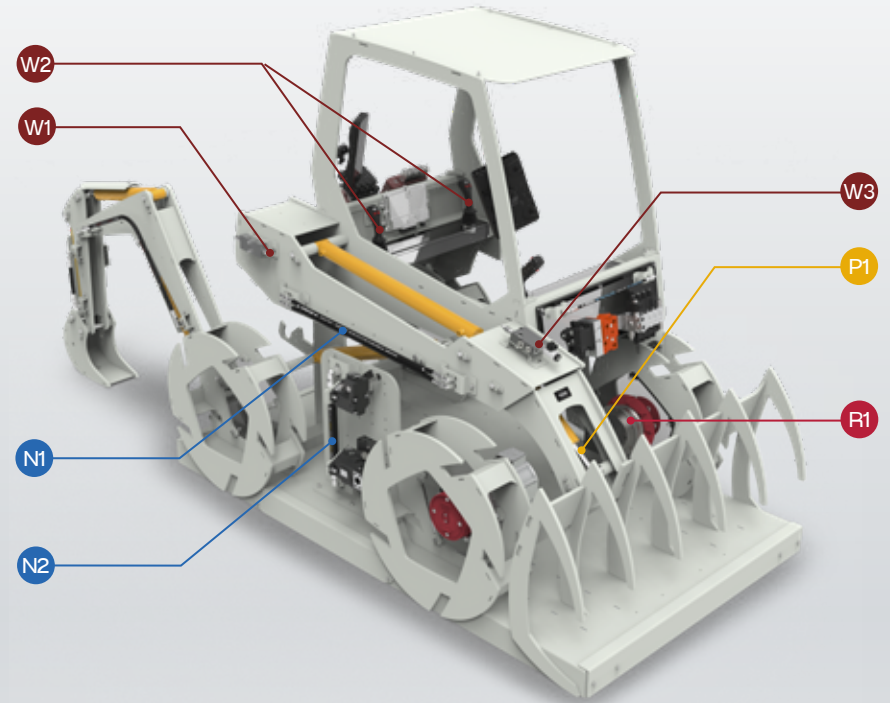

**walvoil** HYDRAULICS

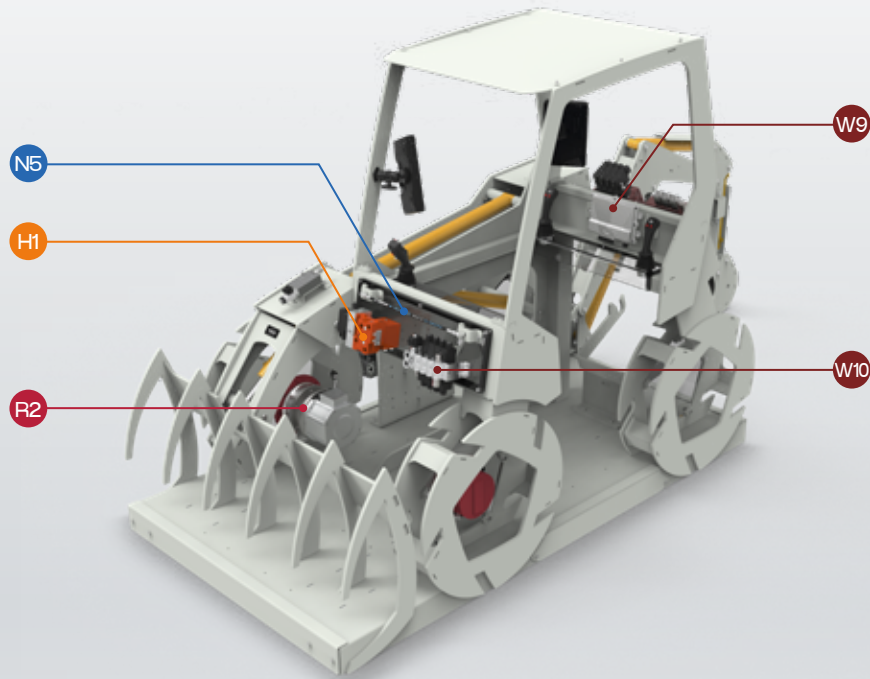

**W9 CED1200S**  
Control unit for safety related applications. With Hardware Category 2, it can be used in applications up to Performance Level d / SIL 2. Programmable through Mathworks® tools, it is completely sealed and protected against water and dust ingress (IP67/IPx9K).



**W10 SDE/SDX Series**  
Bankable solenoid valves. The SDE on/off and SDX proportional series have been developed to offer the market a compact solution with high control performance following the modern needs for high value power density.

**REGGIANA RIDUTTORI** POWER TRANSMISSIONS



**R2 RREDL600**  
RREDL is part of the Edrives Electric wheel drive family, a new range of drive wheels with integrated electric motor, which guarantees maximum performance with all the advantages of electric traction.

**WHITE** HYDRAULICS



**H1 SbX**  
Steering Solution specifically designed for autonomous and advanced vehicles, offering exceptional flexibility, precision, and smart functionality.

**INTERPUMP** FLUID CONVEYANCE



**N5 PILOT FLEX 120 DN 6**  
Hose specifically designed for pilot lines. It ensures high operating pressures and reliable performance in any application.

**walvoil** HYDRAULICS



**W1 VOSL/VODL**  
Counterbalance valves series. Single and double acting, load sensitive and relief compensated up to 160 l/min (5800 psi) and 400 bar (42.3 US gpm).



**W2 CJW + XMH**  
CANbus joystick with handle. Available communication protocols: SAE J1939, CANopen, CANopen safety and ISOBUS. Robust mechanical design specifically tailored to "off-highway" operating machines. XMH handle: multifunction handle for excavators



**W3 E-VBL**  
Electric boom lock valve with proportional configurable metering.

**REGGIANA RIDUTTORI** POWER TRANSMISSIONS



**R1 RRWD600**  
Hydraulic wheel drives available in 18 sizes, offering a compact design, high load strength, axial and radial load capacity, and a variety of ratios.

**Panni** HYDRAULICS



**P1 07\*MK930**  
Telehandler Bucket cylinder. Hydraulic cylinder that controls the movement of the bucket, enabling digging, loading, and dumping operations.

**INTERPUMP** FLUID CONVEYANCE



**N1 LongLift Dual 2SC DN 12**  
High-performance twin rubber hose, designed with advanced engineering and a dedicated manufacturing process to ensure an extremely compact cross-sectional profile, making assembly operations significantly easier.



**N2 HySopress WS 6K DN 25**  
High-performance spiral flexible hose (size: 1" - WP 420 bar). The new HySopress WS line, qualified according to ISO 18752, delivers the same renowned reliability as traditional INTERPUMP hoses, combined with outstanding performance in terms of minimum bending radius and flexibility.



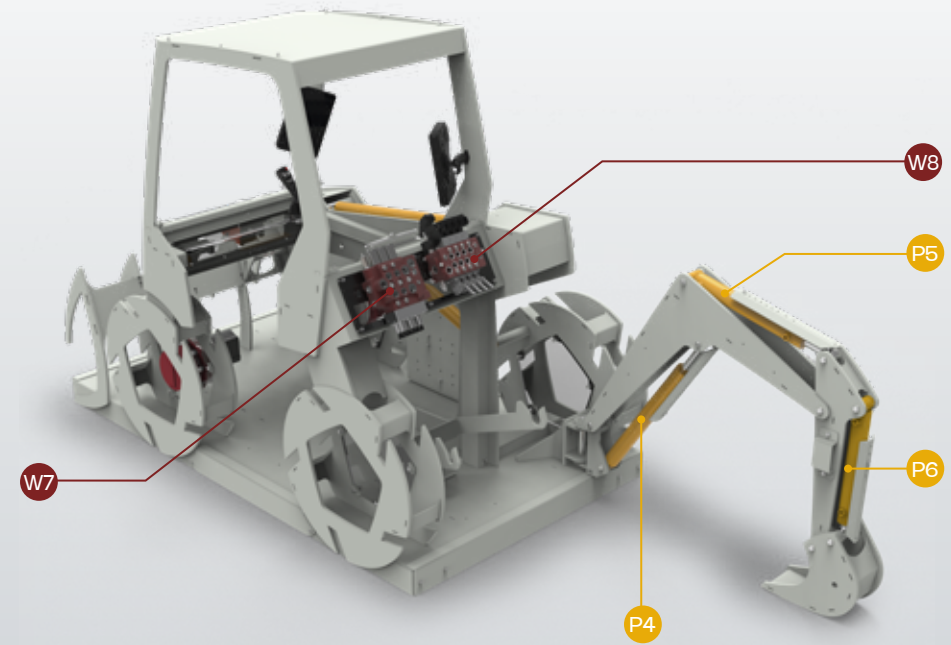
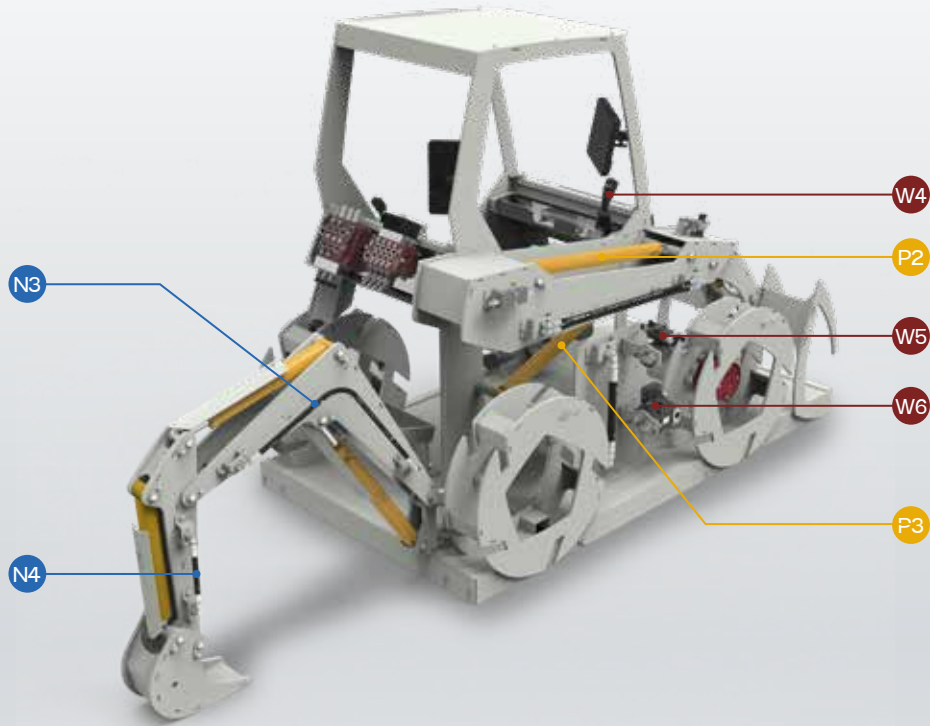

HYDRAULICS

**W4 DJW + MTH**

Joystick for ISOBUS and Safety related applications up to Performance Level d / SIL 2, completely sealed and protected against water and dust ingress (IP67/IPx9K).

MTH handle: ergonomic design, customizable configuration, capacitive operator presence detection.

**W5 2XM/2XMW**

Walvoil Fan Drive is a new range of vehicle cooling systems based on external gear motors. These types of motors are widely used in modern Hydraulics thanks to their performance, long life service and low maintenance costs.

**W6 PWLS + ALS**

Variable Displacement Piston Pumps. PWLS series offers all the features needed for a new generation of mobile hydraulic implement pumps. Ready for ALS adaptive control.



HYDRAULICS

**P2 07\*MK929**

Telehandler Extension cylinder. Hydraulic cylinder that extends and retracts the telescopic boom, allowing the telehandler to reach greater distances during lifting or loading operations.

**P3 07\*MK928**

Telehandler Lift cylinder. Hydraulic cylinder that raises and lowers the boom of the telehandler, enabling vertical load positioning and lifting operations.



FLUID CONVEYANCE

**N3 HySopress wb 5K DN 12**

High-performance braided flexible hose (size: 1/2" - WP 350 bar). The new HySopress WB line, qualified according to ISO 18752, delivers the same proven reliability as traditional INTERPUMP hoses.

**N4 MARATHON 2SC ND 12**

High-performance hose (size: 1/2" - WP 350 bar), exceeding the requirements of EN 857 and ISO 11237.



HYDRAULICS

**W7 SDM150**

Monoblock valve especially designed for Skid Steer Loader applications. Valve with series circuit and manual, hydraulic and proportional electro-hydraulic controls. Optional port lock to prevent accidental load descent.

**W8 DPX Series**

Full Flow Sharing valves, highly configurable and versatile for a wide range of applications. Valve configurations with manual, hydraulic and proportional electro-hydraulic controls. DPX100 is available in HF configuration.



HYDRAULICS

**P4 07\*MK925**

Excavator Boom Lift cylinder. Hydraulic cylinder responsible for lifting and lowering the excavator's boom, providing the main vertical movement for digging operations.

**P5 07\*MK926**

Excavator Arm cylinder. Hydraulic cylinder that controls the movement of the excavator's arm (stick), allowing precise digging and positioning operations.

**P6 07\*MK927**

Excavator Bucket cylinder. Hydraulic cylinder that controls the movement of the bucket, enabling digging, loading, and dumping operations.